

**SKYWALKER SIGNATURE SERIES
NON-PENETRATING ROOF MOUNT BASE (SKY32816)
WITH INTERCHANGEABLE MAST PIPE (SKY32817A- SKY32817D).**

PARTS LIST:

- (6) Angle Iron Frame Pieces (A)
- (4) Tubular Braces (B)
- (1) *Mast Pipe (C) * Sold Separately
- (1) Hardware Kit (D)
 - Contents Of Hardware Kit (D)
 - (3) Long carriage bolts (for mast pipe to base and mast pipe to braces) (D-1)
 - (10) Short carriage bolts (for bolting angle iron frame together and securing tubular braces to angle iron frame pieces). (D-2)
 - (13) Lock Washers (D-3)
 - (13) Nuts (D-4)

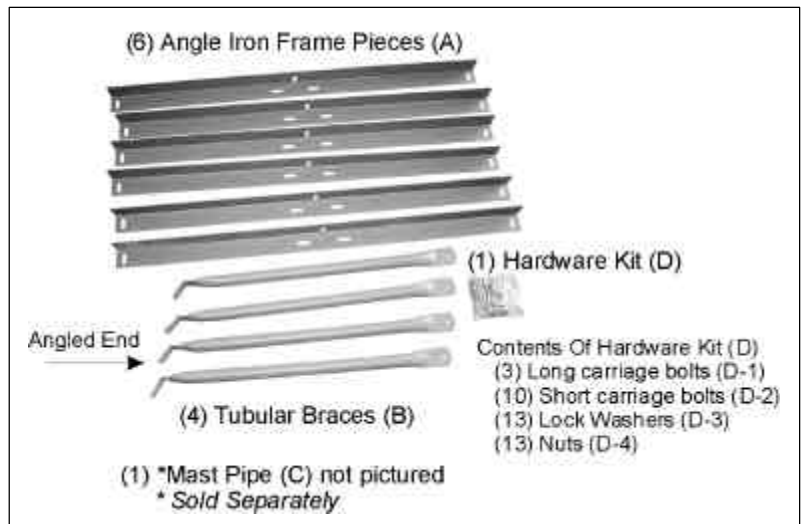

ASSEMBLY INSTRUCTIONS:

- 1) Place the 4 angle iron pieces (A) on the ground or on an optional rubber roof pad (SKYPAD) and line up the holes in the ends of the frame pieces. Place a short carriage bolt (D-2) in each of the 4 corner holes going through both frame pieces with the threads facing up. Place 1 lock washer (D-3) and 1 nut (D-4) on each of the short carriage bolts. Do not fully tighten any of the nuts at this time.
- 2) Place 2 angle iron pieces (A) across the center of the mount with the angles facing away from each other. The holes on each end should line up with the holes in the outer frame piece. Place a short carriage bolt (D-2) through from the bottom of the existing frame piece through the hole in the center cross frame piece. Do the same thing on both ends. Place a lock washer (D-3) and a nut (D-4) on 1 bolt on the left on one end and another on the right at the opposite end. Leave the other two bolts without a washer and nut for now. Do not tighten any of the nuts at this time.
- 3) Place a Tubular brace (B) on one of the center brace bolts that does not have a washer & nut on it. Place the end with the bend on the short carriage bolt. Place a lock washer (D-3) and a nut (D-4) on that short carriage bolt and do the same thing at the opposite end with another tubular brace. Do not tighten any of the nuts at this time.
- 4) Place the mast pipe (C) (SOLD SEPARATELY) in between the two center frame pieces (face the end with the holes nearest the end of the mast toward the base of the mount. Take a long carriage bolt (D-1) and put it through one side of the first angle iron center brace and then through the mast pipe and finally through the other center brace. Place a lock washer (D-3) and nut (D-4) on the long carriage bolt. Do not tighten the nut at this time.
- 5) Take the remaining tubular braces (D) and attach them to the outer angle iron pieces (A) with a short carriage bolt (D-2), a lock washer (D-3) and a nut (D-4). Place the angled end of the tubular brace toward the angle iron brace.
- 6) Align the last two tubular braces (D) with the holes in the mast pipe (C) and place a long carriage bolt through one brace then the pipe and then the other brace. Put a lock washer (D-3) and a nut (D-4) on the long carriage bolt. Do not tighten the nut at this time.
- 7) At this point the mount should be fully assembled. Begin tightening the 4 outer corner nuts on the main base frame. Then tighten the 2 outer tubular braces to the main frame. Next, tighten the 3 long carriage bolts on the mast pipe. Finally, tighten the 4 nuts that hold the center braces and two of the tubular support arms to the outer frame.
- 8) Check the top of the mast on at least two sides to make sure that it is level. Make any necessary adjustments or use some form of shims to level the mast pipe.

